



Industrial Multimeter

**AMM-3031**

**User's Manual**



[www.tmatlantic.com](http://www.tmatlantic.com)

## ***Introduction***

---

This meter measures AC/DC Voltage, AC/DC Current, Resistance, Capacitance, Frequency (electrical & electronic), Duty cycle, Diode Test, Continuity plus Thermocouple Temperature and inductance. Proper use and care of this meter will provide many years of reliable service.

## ***Safety***

---



This symbol adjacent to another symbol, terminal or operating device indicates that the operator must refer to an explanation in the Operating Instructions to avoid personal injury or damage to the meter.

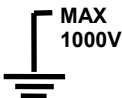

This symbol advises the user that the terminal(s) so marked must not be connected to a circuit point at which the voltage with respect to earth ground exceeds (in this case) 1000 VAC or VDC.



This symbol adjacent to one or more terminals identifies them as being associated with ranges that may, in normal use, be subjected to particularly hazardous voltages. For maximum safety, the meter and its test leads should not be handled when these terminals are energized.



This symbol indicates that a device is protected throughout by double insulation or reinforced insulation.

### **PER IEC1010 OVERVOLTAGE INSTALLATION CATEGORY**

#### ***OVERVOLTAGE CATEGORY I***

Equipment of OVERVOLTAGE CATEGORY I is equipment for connection to circuits in which measures are taken to limit the transient overvoltages to an appropriate low level.

Note – Examples include protected electronic circuits.

#### ***OVERVOLTAGE CATEGORY II***

Equipment of OVERVOLTAGE CATEGORY II is energy-consuming

equipment to be supplied from the fixed installation.

Note – Examples include household, office, and laboratory appliances.

#### *OVERVOLTAGE CATEGORY III*

Equipment of OVERVOLTAGE CATEGORY III is equipment in fixed installations.

Note – Examples include switches in the fixed installation and some equipment for industrial use with permanent connection to the fixed installation.

#### *OVERVOLTAGE CATEGORY IV*

Equipment of OVERVOLTAGE CATEGORY IV is for use at the origin of the installation.

Note – Examples include electricity meters and primary over-current protection equipment

### **SAFETY INSTRUCTIONS**

This meter has been designed for safe use, but must be operated with caution. The rules listed below must be carefully followed for safe operation.

1. **NEVER** apply voltage or current to the meter that exceeds the specified maximum:

Input Protection Limits	
Function	Maximum Input
V DC or V AC	1000VDC/AC rms
mA AC/DC	800mA 1000V fast acting fuse
Frequency, Resistance, Capacitance, Duty Cycle, Diode Test, Continuity	1000VDC/AC rms
Temperature	1000VDC/AC rms
Inductance	30VDC/AC rms

2. **USE EXTREME CAUTION** when working with high voltages.
3. **DO NOT** measure voltage if the voltage on the "COM" input jack exceeds 1000V above earth ground.
4. **NEVER** connect the meter leads across a voltage source while the function switch is in the current, resistance, or diode mode. Doing so can damage the meter.
5. **ALWAYS** discharge filter capacitors in power supplies and disconnect the power when making resistance or diode tests.
6. **ALWAYS** turn off the power and disconnect the test leads before opening the covers to replace the fuse or batteries.
7. **NEVER** operate the meter unless the back cover and the battery and fuse covers are in place and fastened securely.

If the equipment is used in a manner not specified by the manufacturer, the protection provided by the equipment may be impaired.

## Controls and Jacks

---

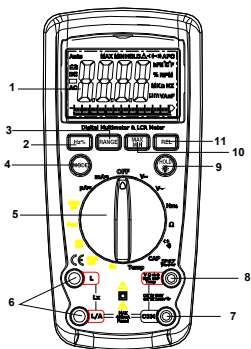

1. 6,000 count LCD display
2. Hz% button
3. RANGE button
4. MODE button
5. Function switch
6. Inductance input jacks
7. COM input jack
8. Positive input jack
9.  Backlight and Hold button
10. MAX/MIN button
11. REL button

**Note:** Tilt stand and battery compartment are on rear of unit.

## Symbols and Annunciators

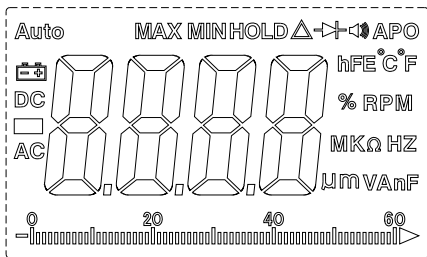

•))) Continuity



Diode test



Battery status

n nano ( $10^{-9}$ ) (capacitance)

$\mu$  micro ( $10^{-6}$ ) (amps, cap)

m milli ( $10^{-3}$ ) (volts, amps)

A Amps

k kilo ( $10^3$ ) (ohms)

F Farads (capacitance)

M mega ( $10^6$ ) (ohms)

$\Omega$  Ohms

Hz Hertz (frequency)

V Volts

REL Relative

AC Alternating current

AUTO Auto ranging

DC Direct current

HOLD Display hold

$^{\circ}$ F Degrees Fahrenheit

$^{\circ}$ C Degrees Centigrade

MAX Maximum

MIN Minimum

AUTO Auto Range

Timing symbol

Backlight

bargraph

## Operating Instructions

**WARNING:** Risk of electrocution. High-voltage circuits, both AC and DC, are very dangerous and should be measured with great care.

1. ALWAYS turn the function switch to the **OFF** position when the meter is not in use.
2. If “OL” appears in the display during a measurement, the value exceeds the range you have selected. Change to a higher range.

## DC VOLTAGE MEASUREMENTS

**CAUTION:** Do not measure DC voltages if a motor on the circuit is being switched ON or OFF. Large voltage surges may occur that can damage the meter.

1. Set the function switch to the “DC” position.
2. Insert the black test lead banana plug into the negative **COM** jack. Insert the red test lead banana plug into the positive **V** jack.
3. Touch the black test probe tip to the negative side of the circuit. Touch the red test probe tip to the positive side of the circuit.
4. Read the voltage in the display.



## AC VOLTAGE MEASUREMENTS

**CAUTION:** Do not measure AC voltages if a motor on the circuit is being switched ON or OFF. Large voltage surges may occur that can damage the meter.

1. Set the function switch to “AC” position.
2. Insert the black test lead banana plug into the negative **COM** jack.  
Insert red test lead banana plug into the positive **V** jack.
3. Touch the black test probe tip to the neutral side of the circuit.  
Touch the red test probe tip to the “hot” side of the circuit.
4. Read the voltage in the display

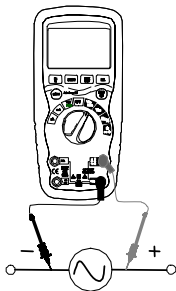

## AC/DC CURRENT MEASUREMENTS

1. Insert the black test lead banana plug into the negative **COM** jack.
2. For current measurements up to  $6000\mu\text{A}$  AC/DC, set the function switch to the  **$\mu\text{A}$**  position and insert the red test lead banana plug into the  **$\mu\text{A}/\text{mA}$**  jack, press mode button to select AC or DC.
3. For current measurements up to  $600\text{mA}$  DC, set the function switch to the **mA** position and insert the red test lead banana plug into the  **$\mu\text{A}/\text{mA}$**  jack, press mode button to select AC or DC.
4. Remove power from the circuit under test, then open up the circuit at the point where you wish to measure current.
5. Touch the black test probe tip to the negative side of the circuit.  
Touch the red test probe tip to the positive side of the circuit.

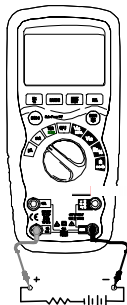



6. Apply power to the circuit.
7. Read the current in the display.

## RESISTANCE MEASUREMENTS

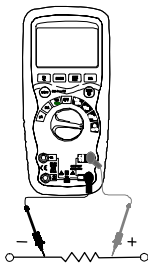

**WARNING:** To avoid electric shock, disconnect power to the unit under test and discharge all capacitors before taking any resistance measurements. Remove the batteries and unplug the line cords.

1. Set the function switch to the  $\Omega$  position.
2. Insert the black test lead banana plug into the negative **COM** jack.  
Insert the red test lead banana plug into the positive  $\Omega$  jack.
3. Touch the test probe tips across the circuit or part under test. It is best to disconnect one side of the part under test so the rest of the circuit will not interfere with the resistance reading.
4. Read the resistance in the display.



## CONTINUITY CHECK

**WARNING:** To avoid electric shock, never measure continuity on circuits or wires that have voltage on them.

1. Set the function switch to the  position.
2. Insert the black lead banana plug into the negative **COM** jack.  
Insert the red test lead banana plug into the positive  $\Omega$  jack.
3. Press the **MODE** button  to indicate " " and " $\Omega$ " on the display
4. Touch the test probe tips to the circuit or wire you wish to check.

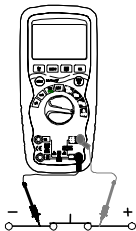

- If the resistance is less than approximately  $30\Omega$ , the audible signal will sound. If the circuit is open, the display will indicate "OL".

## DIODE TEST

- Set the function switch to the  $\rightarrow \rightarrow \rightarrow$  position.
- Insert the black test lead banana plug into the negative **COM** jack and the red test lead banana plug into the positive **V** jack.
- Press the **MODE** button to indicate " $\rightarrow \rightarrow \rightarrow$ " and "**V**"  $\square\square\square\square$  on the display.
- Touch the test probes to the diode under test. Forward voltage will typically indicate 0.400 to 0.700V. Reverse voltage will indicate "OL". Shorted devices will indicate near 0V and an Open device will indicate "OL" in both Polarities.

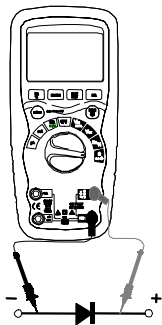

## CAPACITANCE MEASUREMENTS

**WARNING:** To avoid electric shock, disconnect power to the unit under test and discharge all capacitors before taking any capacitance measurements. Remove the batteries and unplug the line cords.

- Set the rotary function switch to the **CAP** position.
- Insert the black test lead banana plug into the negative **COM** jack.
- Insert the red test lead banana plug into the positive **V** jack.
- Touch the test leads to the capacitor to be tested.  
Read the capacitance value in the Display



## TEMPERATURE MEASUREMENTS

1. Set the function switch to the “Temp” positive and press the MODE key to select the “°C” measuring or “°F” measuring.
2. Insert the Temperature Probe into the input jacks, making sure to observe the correct polarity.
3. Touch the Temperature Probe head to the part whose temperature you wish to measure. Keep the probe touching the part under test until the reading stabilizes (about 30 seconds).
4. Read the temperature in the display.

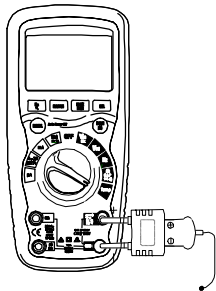

**Note:** The temperature probe is fitted with a type K mini connector.

A mini connector to banana connector adaptor is supplied for connection to the input banana jacks.

## FREQUENCY MEASUREMENT

1. Set the function switch to the Hz/Duty position.
2. Insert the black test lead banana plug into the negative (-) jack (COM) and the red test lead banana plug into the positive (+) jack (F).
3. Touch the test probe tips to the circuit under test.
4. Read the frequency in the display. The digital reading will indicate the proper decimal point, symbols (Hz, kHz, MHz) and value.

**NOTE:** Press the mode key to select the frequency or the duty cycle measuring.

## INDUCTANCE MEASUREMENT

**WARNING:** To avoid electric shock, disconnect both test probes from any source of voltage before making a inductance measurement.

1. If you wish to measure inductance, set the function switch to the inductance position.
2. Insert the black test lead banana plug into L/A input jack for inductance measurements and the red test lead banana plug into L input jack for inductance measurements.
3. Touch the inductance Probe head to the part whose inductance you wish to measure. Keep the probe touching the part under test until the reading stabilizes (about 10 seconds).
4. Read the temperature in the display. The digital reading will indicate the proper decimal point and value.  
NOTICE: When test small inductance (<600uH), please make sure the test leads short circuit, and press REL button then to test.

**WARNING:** To avoid electric shock, be sure the inductance has been removed before changing to another measurement function.

## MODE BUTTON

1. To select DC/AC current or Diode/Continuity or °C /°F or Hz/duty
2. Press the key then turn on the power, the Auto Power-off function will be cancelled, the sign "APO" disappears in the LCD; and enters into the sleep status (power-off), press the key then power on will have Auto Power-off function.

## DATA HOLD BUTTON

The Data Hold function allows the meter to "freeze" a measurement for later reference.

1. Press the DATA HOLD button to "freeze" the reading on the indicator. The indicator "HOLD" will be appears in the display.
2. Press the DATA HOLD button to return to normal operation.

3. Press the DATA HOLD button to last 2 second, the blue back light function is enabled or disenabled.

## **RANGE BUTTON**



When the meter is first turned on, it automatically goes into Auto Ranging. This automatically selects the best range for the measurements being made and is generally the best mode for most measurements. For measurement situations requiring that a range be manually selected, perform the following:

1. Press the RANGE button. The “AUTO” display indicator will turn off.
2. Press the RANGE button to step through the available ranges until you select the range you want.
3. Press and hold the RANGE button for 2 seconds to Exit the Manual Ranging mode and return to Auto Ranging.

## **MAX/MIN BUTTON**

The meter displays the maximum or minimum value of input in the Max/Min mode. When Max/Min is pressed for the first time, the meter displays the maximum value. The meter displays the minimum value when it is pressed again. When Max/Min is pressed for the third time, the meter displays current value. The meter returns to normal operation when Max/Min is pressed and held for longer than one second. Press HOLD key in Max/Min mode makes the meter stop updating the maximum or the minimum value.

## **LOW BATTERY INDICATION**

When the  icon appears alone in the display  , the battery should be replaced.

## Maintenance

**WARNING:** To avoid electric shock, disconnect the test leads from any source of voltage before removing the back cover or the battery or fuse covers.

**WARNING:** To avoid electric shock, do not operate your meter until the battery and fuse covers are in place and fastened securely.

This Multi Meter is designed to provide years of dependable service, if the following care instructions are performed:

1. **KEEP THE METER DRY.** If it gets wet, wipe it off.
2. **USE AND STORE THE METER IN NORMAL TEMPERATURES.** Temperature extremes can shorten the life of the electronic parts and distort or melt plastic parts.
3. **HANDLE THE METER GENTLY AND CAREFULLY.** Dropping it can damage the electronic parts or the case.
4. **KEEP THE METER CLEAN.** Wipe the case occasionally with a damp cloth. DO NOT use chemicals, cleaning solvents, or detergents.
5. **USE ONLY FRESH BATTERIES OF THE RECOMMENDED SIZE AND TYPE.** Remove old or weak batteries so they do not leak and damage the unit.
6. **IF THE METER IS TO BE STORED FOR A LONG PERIOD OF TIME,** the batteries should be removed to prevent damage to the unit.

## BATTERY INSTALLATION

**WARNING:** To avoid electric shock, disconnect the test leads from any source of voltage before removing the battery cover.

1. Turn power off and disconnect the test leads from the meter.
2. Open the rear battery cover by removing two screws (B) using a Phillips head screwdriver.

3. Insert the battery into battery holder, observing the correct polarity.
4. Put the battery cover back in place. Secure with the screws.

**WARNING:** To avoid electric shock, do not operate the meter until the battery cover is in place and fastened securely.

**NOTE:** If your meter does not work properly, check the fuses and batteries to make sure that they are still good and that they are properly inserted.

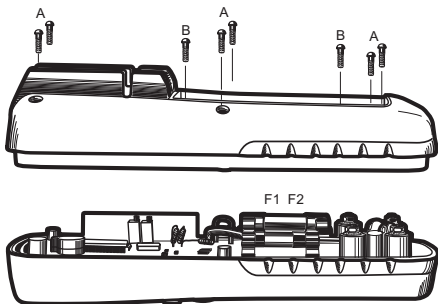

## Specifications

---

### DC Voltage (Auto-ranging)

Range	Resolution	Accuracy
600.0mV	0.1mV	$\pm 0.1\%$ of rdg $\pm 2$ digits
6.000V	1mV	
60.00V	10mV	
600.0V	100mV	
1000V	1V	$\pm 0.3\%$ of rdg $\pm 2$ digits

Input Impedance: 10M $\Omega$ .

Maximum Input: 1000V dc or 1000V ac rms.

### AC Voltage (Auto-ranging)

Range	Resolution	Accuracy
6.000V	1mV	$\pm 0.8\%$ of rdg $\pm 4$ digits
60.00V	10mV	
600.0V	100mV	
1000V	1V	$\pm 1.2\%$ of rdg $\pm 4$ digits

All AC voltage ranges are specified from 5% of range to 100% of range

Input Impedance: 10M $\Omega$ .

AC Response: 50 Hz to 400Hz

Maximum Input: 1000V dc or 1000V ac rms.

### DC Current (Auto-ranging)

Range	Resolution	Accuracy
600.0uA	0.1uA	$\pm 0.8\%$ of rdg $\pm 3$ digits
6000uA	1uA	
60.00mA	10uA	
600.0mA	100uA	$\pm 1.2\%$ of rdg $\pm 3$ digits
10A	10mA	$\pm 1.8\%$ of rdg $\pm 3$ digits

Overload Protection: FF800mA / 1000V and F10A / 1000V Fuse.

Maximum Input:  
6000uA dc on uA range  
800mA dc on mA range  
10A dc on 10A range.



**AC Current (Auto-ranging)**

Range	Resolution	Accuracy
600.0uA	0.1uA	±1.0% of rdg ± 3 digits
6000uA	1uA	
60.00mA	10uA	
600.0mA	100uA	+1.2% of rdg + 3digits
10A	10mA	+2.0% of rdg + 3 digits

All AC Current ranges are specified from 5% of range to 100% of range

Overload Protection: FF800mA/1000V and F10A/1000V Fuse.

AC Response: 50 Hz to 400 Hz

Maximum Input:           6000uA ac rms on uA  
                                   800mA ac rms on mA  
                                   10A ac rms on 10A range

**Resistance [Ω] (Auto-ranging)**

Range	Resolution	Accuracy
600.0Ω	0.1Ω	+0.5% of rdg ± 4 digits
6.000kΩ	1Ω	±0.5% of rdg ± 2 digits
60.00kΩ	10Ω	
600.0kΩ	100Ω	
6.000MΩ	1kΩ	±1.5% of rdg ±8digits
60.00MΩ	10kΩ	

Input Protection: 1000V dc or 1000V ac rms.

**Capacitance (Auto-ranging)**

Range	Resolution	Accuracy
40.00nF	10pF	+5.0% of rdg ± 20 dgts
400.0nF	0.1nF	±3.0% of rdg ± 5 dgts
4.000uF	1nF	
40.00uF	10nF	
400.0uF	0.1uF	
4000uF	1uF	±5.0% of rdg ± 10 dgts

Input Protection: 1000V dc or 1000V ac rms.

### Frequency (Auto-ranging)

Range	Resolution	Accuracy
9.999Hz	0.001Hz	±1.2% of rdg ± 3 dgts
99.99 Hz	0.01Hz	
999.9 Hz	0.1Hz	
9.999KHz	1 Hz	
99.99kHz	10Hz	
999.9kHz	100Hz	±1.5% of rdg ± 4 dgts
9.999MHz	1kHz	

Sensitivity: >0.5V RMS while ≤1MHz ;

Sensitivity: >3V RMS while >1MHz;

Input Protection: 1000V dc or 1000V ac rms.

### Duty Cycle

Range	Resolution	Accuracy
0.1%~99.9%	0.1%	±1.2% of rdg ± 2 digits

Pulse width: >100us, <100ms;

Frequency width: 5Hz – 150 kHz

Sensitivity: <0.5V RMS

Overload protection: 1000V dc or ac rms.

### Temperature

Range	Resolution	Accuracy
-20°C ~+400°C	0.1 °C	± 3% of rdg ± 5 °C
400°C ~+1000°C	1 °C	
-4 °F ~+752 °F	0.1°F	± 3% of rdg ± 8 °F
752°F ~+1832 °F	1°F	

Sensor: Type K Thermocouple

Overload protection: 1000V dc or ac rms..

### Diode Test

Test current	Resolution	Accuracy
0.3mA typical	1 mV	±10% of r dg ± 5 digits

Open circuit voltage: MAX. 2V dc

Overload protection: 1000V dc or ac rms.

### Audible continuity

Audible threshold: Less than  $30\Omega$  Test current MAX. 0.3mA

Overload protection: 1000V dc or ac rms.

### Inductance (Manual-ranging)

Range	Resolution	Accuracy	Test frequency
600.0uH	0.1uH	$\pm 3.0\%$ of rdg $\pm 3\mu\text{H}$	About 2.2KHZ
6 . 0 0 0 mH	1uH	$\pm 3.0\%$ of rdg $\pm 5$ dgt	About 220HZ
6 0 . 0 0 mH	10uH	$\pm 3.0\%$ of rdg $\pm 5$ dgt	About 220HZ
600.0m H	100uH	$\pm 3.0\%$ of rdg $\pm 5$ dgt	About 220HZ
6.000H	1mH	$\pm 3.0\%$ of rdg $\pm 5$ dgt	About 220HZ

Maximum Input: 30V dc or 30V ac rms.

NOTICE: When test small inductance (<600uH), please make sure the test leads short circuit, and press REL button then to test.

**Store capacitance** 2000

**Enclosure** Double molded, waterproof

**Shock (Drop Test)** 6.5 feet (2 meters)

**Diode Test** Test current of 0.9mA maximum, open circuit voltage 2V DC typical

**Continuity Check** Audible signal will sound if the resistance is less than  $30\Omega$  (approx.), test current <0.3mA

**Temperature Sensor** Requires type K thermocouple

**Input Impedance**  $>10\text{M}\Omega$  VDC &  $>9\text{M}\Omega$  VAC

**ACV Bandwidth** 50Hz to 400Hz

**Crest Factor**  $\leq 3$  at full scale up to 500V, decreasing linearly to  $\leq 1.5$  at 1000V

**Display** 6000 count backlit liquid crystal with

## Bar graph

**Over range indication** “OL” is displayed

### **NON-CONTACT VOLTAGE (NCV):**

The NCV function works on any rotary switch position.

1. Test the detector on a known live circuit before use.
2. Hold the top of the meter very close to the voltage source as shown.
3. If voltage is present, the back light will flash a bright red.

**Auto Power Off**

15 minutes (approximately) with disable feature

**Polarity**

Automatic (no indication for positive); Minus (-) sign for negative

**Measurement Rate**

2 times per second, nominal

**Low Battery Indication**

“  ” is displayed if battery voltage drops below operating voltage

**Battery**

One 9 volt (NEDA 1604) battery

**Fuses**

mA,  $\mu$ A ranges; 0.8A/1000V ceramic fast blow A range; 10A/1000V ceramic fast blow

**Operating Temperature**

41°F to 104°F (5°C to 40°C)

**Storage Temperature**

-4°F to 140°F (-20°C to 60°C)

**Operating Humidity**

Max 80% up to 87°F (31°C) decreasing linearly to 50% at 104°F (40°C)

**Storage Humidity**

<80%

**Operating Altitude**

7000ft. (2000meters) maximum.

**Weight**

0.753lb (342g) (includes holster).

**Size**

7.36" x 3.2" x 2.0" (187 x 81 x 50mm) (include holster)

**Safety**

This meter is intended for origin of installation use and protected, against the users, by double insulation per EN61010-1 and IEC61010-1 2<sup>nd</sup> Edition (2001) to Category IV 600V and Category III 1000V; Pollution Degree 2. The meter also meets UL 61010-1, 2<sup>nd</sup> Edition (2004), CAN/CSA C22.2 No. 61010-1 2<sup>nd</sup> Edition (2004), and UL 61010B-2-031, 1<sup>st</sup> Edition (2003)