

Green power, hybrid power

SMART MULTIMETER

 **AKTAKOM** Model : **AMM-1081**

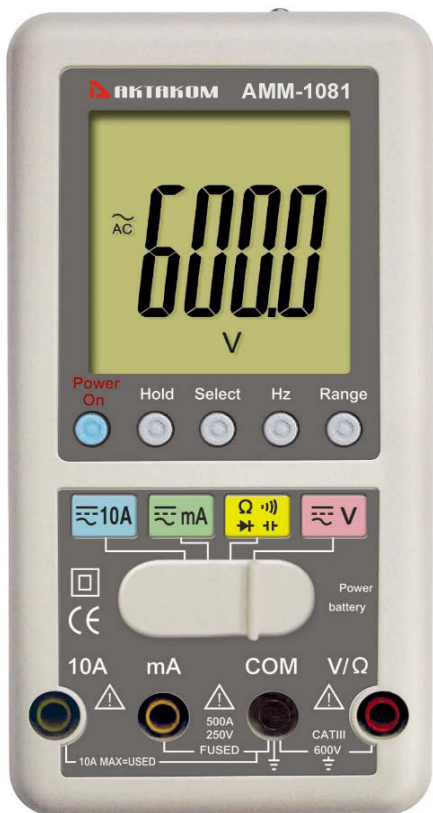

Your purchase of this SMART MULTIMETER marks a step forward for you into the field of precision measurement. Although this MULTIMETER is a complex and delicate instrument, its durable structure will allow many years of use if proper operating techniques are developed. Please read the following instructions carefully and always keep this manual within easy reach.



OPERATION MANUAL

www.tmatlantic.com

Caution Symbol



Caution :

- * Risk of electric shock !



Caution :

- * Do not apply the overload voltage, current to the input terminal !
- * Remove test leads before open the battery cover !
- * Cleaning - Only use the dry cloth to clean the plastic case !

Environment Conditions

** Installation Categories III 600V.*

** Pollution Degree 2.*

** Altitude up to 2000 meters.*

** Indoor use.*

** Relative humidity 80% max.*



Equipment protected throughout by double insulation or reinforced insulation.

TABLE OF CONTENTS

1. FEATURES.....	1
2. SPECIFICATIONS.....	2
3. FRONT PANEL DESCRIPTION.....	6
3-1 Display.....	6
3-2 Power ON button.....	6
3-3 Hold button.....	6
3-4 Select button.....	6
3-5 Hz button.....	6
3-6 Range button	6
3-7 Function switch.....	6
3-8 V/ Ω terminal	6
3-9 COM terminal	6
3-10 mA terminal.....	6
3-11 10 A terminal.....	6
3-12 Handle of power generator.....	6
3-13 Stand.....	6
3-14 Battery compartment/cover.....	6
3-15 Power type switch (G/B switch).....	6
4. POWER TYPE SELECTION.....	6
MEASURING PROCEDURE.....	8
5-1 Precautions & preparations for measurement.....	8
5-2 Power management.....	8
5-3 Symbols & Units of Display	9
5-4 Voltage (ACV/DCV) measurement.....	10
5-5 Resistance measurement.....	10
5-6 Continuity, Diode measurement.....	10
5-7 Capacitance measurement.....	12
5-8 Current mA (AC/DC) measurement.....	13
5-9 Current 10A (AC/DC) measurement.....	13
5-10 Smart/Auto function selection.....	14
5-11 Range selection.....	14
5-12 Hz measurement.....	15
5-13 Data Hold.....	15
6. MAINTENANCE.....	15
7. OPTIONAL ACCESSORIES & ADAPTERS	17
8. PATENT.....	17
9. THE ADDRESS OF AFTER SERVICE CENTER.....	18

1. FEATURES

- * Green power, battery is no need, power supply from the handy generator, operate the generator 10 to 20 seconds will offer 10 minutes energy typically.
- * Hybrid power, meter also can supply by the battery.
- * Meet CAT III-600 V.
- * 6000 counts A/D, high resolution.
- * ACV, ACA, DCV, DCA, ohms, continuity, Hz, Capacitance, Diode, Data hold.
- * Smart function, Auto range or manual range with hold.
- * Smart operation, Build in 4 intelligent function :
" V ", " Ω ", " mA ". " 10A ".
- * " V " function can select ACV, DCV automatically with auto range.
- * " Ω " function can select the Resistance , Diode, Continuity beeper, Capacitance automatically with auto range.
- * " 10A " " mA " function can measure ACA, DCA with auto range.
- * Data hold (auto range).
- * Auto shut off is available to save battery life.
- * Both 10 A, mA current range are build fuses for safety consideration.
- * 10 M ohm impedance for voltage circuit.
- * Built-in overload protection for most ranges.
- * LSI circuit provides high reliability and durability.
- * Patent.
- * Uses durable, long-lasting components, enclosed in strong, light weight ABS-plastic housing.
- * Full line optional adapters : Clamp adapter, Tachometer adapter, Pressure adapter, Humidity Adapter, Sound level adapter, Anemometer adapter, Light adapter, EMF adapter.

2. SPECIFICATIONS

2-1 General Specifications

Green power and Hybrid power	<p>* Green power, battery is no need, power supply from the handy generator, operate 10 to 20 seconds the generator will offer 10 minutes energy typically.</p> <p>* Hybrid power, meter also can supply by the battery power.</p>
Display	46 mm x 45 mm large LCD display.
Measurement	ACV, ACA, DCV, DCA, ohms, continuity beeper, Hz, Capacitance, Diode, Data hold.
A/D counts no.	6000 counts.
Range selection	Smart function, auto range or manual range selecting.
Smart function	" V " function can select ACV, DCV automatically with auto range.
	" Ω " function can select the Resistance, Diode, Continuity beeper, Capacitance automatically with auto range.
	" 10A " " mA " function can measure ACA, DCA with auto range.
Data hold	To freeze the display reading on the LCD display. <i>* Available for auto range only.</i>
Power On/Off management	If meter is not operated within 3 minutes will auto power switch off.
Polarity	Automatic Switching, " - " indicates negative polarity.
Sampling time	Approx. 0.5 to 1 second.
Operating Temperature	0 to 50 °C (32 to 122 °F).

Operating humidity	Less than 80% RH.
Power Supply	Green power : Power from the handy generator, battery is no need.
	Battery power : DC 3V battery (CR-2032) x 2 PCs.
Power consumption	DC 3 mA.
Weight	340 g/0.75 LB.
Dimension	152 x 78 x 45 mm (6.0 x 3.1 x 1.8 inch)
Accessories Included	Red and Black Test Leads..... 1 Set Instruction Manual..... 1 PC
Optional accessories	Full line adapters : ACA/DCA current adapter, Tachometer adapter, Humidity adapter, Pressure adapter, Light adapter, EMF adapter, Sound level adapter, High voltage probe.

2-2 Electrical specifications (23± 5°C)

<i>DC/AC Voltage</i> * auto range	
Range	6 V /60 V/600 V
Resolution	0.001 V /0.01 V/0.1 V
Accuracy	DCV : ± (1 % + 2d)
	ACV : ± (1.2 % + 5d)
Input impedance	10 M ohm.
Over load protection	AC/DC 600 V.
Remark	* <i>The input impedance is 10 Mega ohm.</i> * <i>ACV specification be tested on sine wave 50/60 Hz.</i> * <i>For smart function ,the ACV start measurement voltage is larger than 400 mV ± 100 mV.</i>

DC/AC Current		* auto range
Range	mA range	600 mA/60 mA
	10 A range	10A
Resolution	mA range	0.1 mA/0.01 mA
	10 A range	0.01 A
Accuracy	mA range	$\pm (1.2\% + 2d)$
	10 A range	$\pm (1.5\% + 2d)$
Over load protection	mA range	630 mA fuse
	10 A range	10 A fuse
Remark	<p><i>* ACA specification be tested on sine wave 50/60 Hz.</i></p> <p><i>* For smart function ,the ACA start measurement is</i></p> <p>10 A range : 1.50 A.</p> <p>mA range : 1.50 mA.</p>	

OHMS		* auto range
Range	600/6 K/60 K/600 K/6 M ohm	
Resolution	0.1/1/10/100/1 K ohm	
Accuracy	$\pm (1\% + 3d)$	
Over load protection	± 350 DCV, 350 ACV	

Capacitance		* auto range
Range	6 nF/60 nF/600 nF/6 uF/60 uF	
Resolution	0.001 nF/0.01 nF/0.1 nF/0.001 uF/0.01 uF	
Accuracy	$\pm (3\% + 5d)$	
Remark	<i>Discharge capacitor before testing.</i>	

Frequency		* auto range
Range	40 Hz to 1 KHz.	
Resolution	1 Hz.	
Accuracy	$\pm (0.3\% + 2d)$	
Input impedance	10 M ohm.	
Over load protection	AC/DC 600 V.	

Diode

Short/non conductance, good/defect test.

Continuity

If measuring resistance is less than 10 ohm, the beeper will sound .

3. FRONT PANEL DESCRIPTION

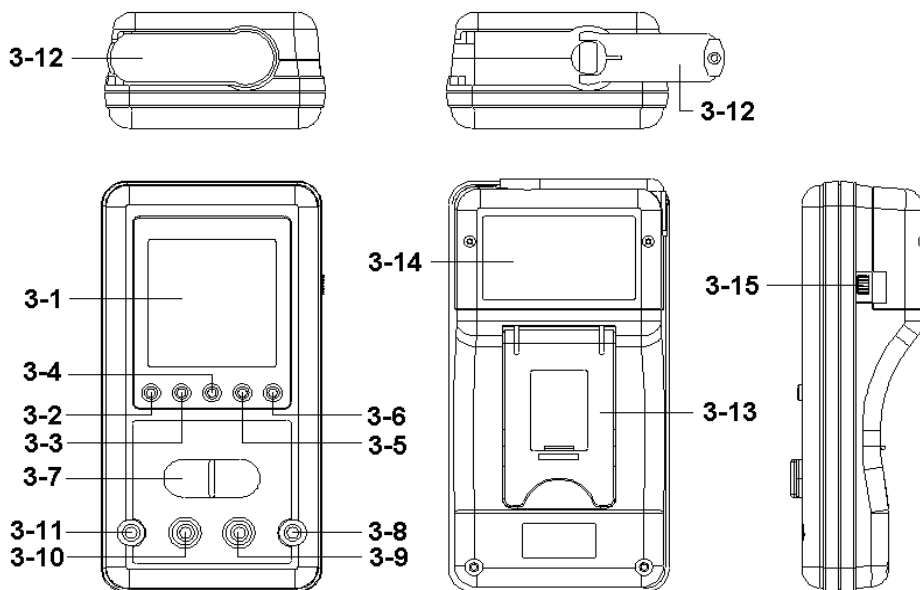

Fig. 1

- 3-1 Display
- 3-2 Power On button.
- 3-3 Hold button
- 3-4 Select button
- 3-5 Hz button
- 3-6 Range button
- 3-7 Function switch
- 3-8 V/ Ω terminal
- 3-9 COM terminal
- 3-10 mA terminal
- 3-11 10 A terminal
- 3-12 Handle of power generator
- 3-13 Stand
- 3-14 Battery compartment/cover
- 3-15 Power type switch (G/B switch)

4. POWER TYPE SELECTION

4-1 Power supply from the generator (Green power supply)

- 1) Select the " Power type switch " (3-15, Fig. 1) to the " G position " (Green power position).

There is a " Power generator's handle " (3-12, Fig. 1) on the top of the housing case.

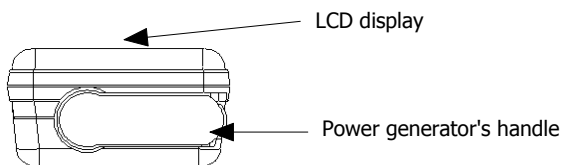

- 2) Lift and extend the " Power generator's handle " and rotate the handle in clockwise direction will generate the power energy into the meter, refer to Fig. a, b, c.

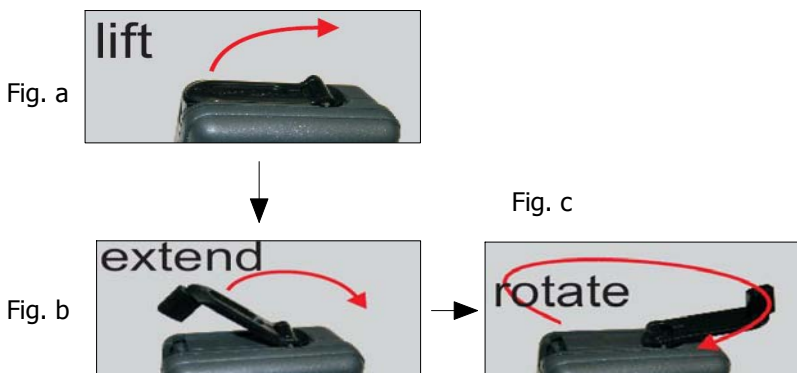

- c. Wind-up the generator 10 to 20 seconds will offer 10 minutes energy typically. If wind-up the generator more time, the meter will be saved more energy and let the meter be operated for a long period.

4-2 Power supply from the battery

- 1) Install the " DC3V battery (CR-2032) x 2 PCs " into the " Battery compartment " (3-14, Fig. 1)
- 2) Slide the " Power type switch " to the " B " position (battery position), the meter will offer the power source from the battery.

5. MEASURING PROCEDURE

5-1 precautions & preparations for measurement









- 1) Place the Red & Black Test Leads into the proper input terminal before making measurement.
- 2) Remove either of the test leads from the circuit when changing the measurement range.
- 3) Do not exceed the maximum rated voltage and current to the input terminal.
- 4) For safety consideration, when change the new test leads, it should use the replace approval test leads.

5-2 Power management

- 1) Pressing the " Power On button " (3-2, Fig. 1) once, the meter will be power On.
- 2) The meter will be power Off automatically within 3 minutes after power On.

5-3 Symbols & units of display

Symbols Units	Descriptions
SMART	Appears when selecting " Smart " mode. The meter default mode is " Smart "
AUTO	Appears when selecting " Automatic range " mode.
MANU	Appears when selecting " Manual range " mode.
	Appears when selecting DC mode. (DC voltage or DC current)
	Appears when selecting AC mode. (AC voltage or AC current)
	* Appears when the " Data hold " function is operated. * " Data hold " function is executed on the Automatic range " or " Manual mode " mode.
	Power voltage is already under the low condition.
	Appears when the " Continuity beeper " is operated.
V	Units for voltage measurements.
mA,A	Units for " Current " measurement.
Ω ,K Ω ,M Ω	Units for resistance measurements.
nF,uF	Units for " Capacitance " measurement.
KHz	Units for " Frequency " measurement.
	Appears when the " Diode " function is operated.
—	Appears when measuring a DCV or DCA value is negative.
OL	Over range indicator for voltage and current, ohm function.

5-4 Voltage (ACV/DCV) measurement

- 1) Connect BLACK test lead into " COM " terminal (3-9, Fig. 1).
- 2) Connect RED test lead into " V " terminal (3-8, Fig. 1).
- 3) Select the " Function switch " (3-7, Fig. 1) to the " V " position.
- 4) Power On the meter by pressing the " Power On button " (3-2, Fig. 1) once, the Display will show " SMART ", the meter is under " Smart " mode for voltage measurement.
- 5) The meter can measure the ACV, DCV value automatically and with auto range selection.

5-5 Resistance measurement

- 1) Connect BLACK test lead into " COM " terminal (3-9, Fig. 1).
- 2) Connect RED test lead into " Ω " terminal (3-8, Fig. 1).
- 3) Select the " Function switch " (3-7, Fig. 1) to the " Ω " position.
- 4) Power On the meter by pressing the " Power On button " (3-2, Fig. 1) once, the Display will show " SMART ", the meter is under " Smart " mode for resistance measurement.
- 5) The meter can measure the resistance value automatically and with auto range selection.

5-6 Continuity, Diode measurement

Continuity measurement

- 1) Connect BLACK test lead into " COM " terminal (3-9, Fig. 1).
- 2) Connect RED test lead into " Ω " terminal (3-8, Fig. 1).
- 3) Select the " Function switch " (3-7, Fig. 1) to the " $\bullet \rightarrow$ " position.
- 4) Power On the meter by pressing the " Power On button " (3-2, Fig. 1) once, the Display will show " SMART ", the meter is under " Smart " mode for Continuity measurement.

5) When the resistance value is less than 10 ohm, the beeper sound will be generated, the Display will show "  " indicator.

Diode measurement

- 1) Connect BLACK test lead into " COM " terminal (3-9, Fig. 1).
- 2) Connect RED test lead into " Ω " terminal (3-8, Fig. 1).
- 3) Select the " Function switch " (3-7, Fig. 1) to "  " position.
- 4) Power On the meter by pressing the " Power On button " (3-2, Fig. 1) once, the Display will show " SMART ", the meter is under " Smart " mode for Diode measurement.
- 5) a. When connected with polarity as shown in Fig. 2, a forward current flow is established and the approx. Diode Forward Voltage (VF) value in volt will appears on the display reading. If the diode under test is defective, " .000 " or near " .000 " value (short circuit) or " OL " (open circuit) will be displayed.

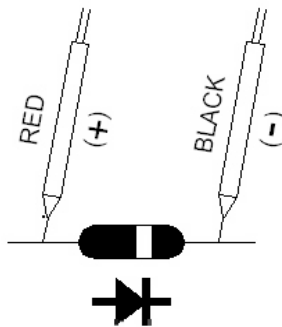

Fig. 2

- b. When connected as shown in Fig. 3, a reverse check on the diode is made. If the diode under test is good, " OL " will be displayed. If the diode under test is defective, ".000 " or other numbers will be displayed. Proper diode testing should include both steps a. and b. above.

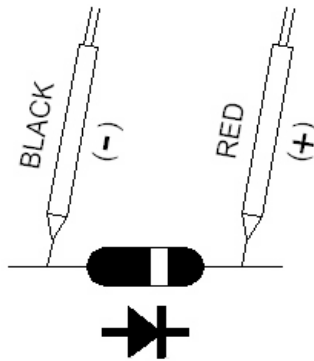

Fig. 3

5-7 Capacitance Measurement

- 1) Connect BLACK test lead into " COM " terminal (3-9, Fig. 1).
- 2) Connect RED test lead into " Ω " terminal (3-8, Fig. 1).
- 3) Select the " Function rotary switch " (3-7, Fig. 1) to the " || " position.
- 4) Power On the meter by pressing the " Power On button " (3-2, Fig. 1) once, the Display will show " SMART ", the meter is under " Smart " mode for capacitance measurement.
- 5) The meter can measure the capacitance value automatically and with auto range selection.

5-8 Current mA (AC/DC) measurement

- 1) Connect BLACK test lead into " COM " terminal (3-9, Fig. 1).
- 2) Connect RED test lead into " mA " terminal (3-10, Fig. 1).
Open the circuit in which current is to be measured. Now securely connect test leads in series with the load in which the current is be measured.
- 3) Select the " Function switch " (3-7, Fig. 1) to the " mA " position.
- 4) Power On the meter by pressing the " Power On button " (3-2, Fig. 1) once, the Display will show " SMART ", the meter is under " Smart " mode for AC mA, DC mA measurement.
- 5) The meter can measure the AC mA, DC mA value automatically and with auto range selection (60 mA, 600 mA).



The max. measurement current for the mA range should less than 600 mA, otherwise the protection fuse will be broken.

5-9 Current 10A (AC/DC) measurement

- 1) Connect BLACK test lead into " COM " terminal (3-9, Fig. 1).
- 2) Connect RED test lead into " 10 A " terminal (3-11, Fig. 1).
Open the circuit in which current is to be measured. Now securely connect test leads in series with the load in which the current is be measured.

- 3) Select the " Function switch " (3-7, Fig. 1) to the " 10 A " position.
- 4) Power On the meter by pressing the " Power On button " (3-2, Fig. 1) once, the Display will show " SMART ". the meter is under " Smart " mode for ACA, DCA.
- 5) The meter can measure the ACA, DCA value with 10 A range.



The max. measurement current for the 10 A range should be less than 10 A, otherwise the protection fuse will be broken.

5-10 Smart/Auto function selection

When the Display shows the " SMART ", the meter is ready for the Smart mode. Under the " Smart " mode if you press the " Select button " (3-4, Fig. 1) once (or once in sequence) then you can select the individual function, for example ACV, DCV, ACA, DCA, Diode, Capacitance, Continuity...testing. In the same time the Display will show the " AUTO " indicator (auto range) or " MANU " indicator (manual range).

5-11 Range selection

Under the " Auto range " mode (Display shows the " AUTO " indicator), if you press the " Range button " (3-6, Fig. 1) once (or once in sequence) then you can select the desired range (manual range) and also hold the measurement range.

5-12 Hz measurement

During the measurement :

Voltage (ACV/DCV) measurement (Chapter 5-4)

Current mA (AC/DC) measurement (Chapter 5-8)

current 10A (AC/DC) measurement (Chapter 5-9)

if press the " Hz button " (3-5, Fig. 1) once, the Display will show " AUTO " and " Hz " indicator, now the meter is ready for frequency measurement of the measurement signal with auto range indication.

5-13 Data Hold

- 1) During the auto range measurement (Display show " AUTO " indicator), if pressing the " Hold button " (3-3, Fig. 1) once will freeze the measured value and the LCD will indicate "  " symbol.
- 2) Push the " Hold Button " again to cancel the data hold function.

6. MAINTENANCE



Caution : *Remove test leads before opening the battery cover or housing case !*

6-1 Cleaning



Caution : *Cleaning - Only use the dry cloth to clean the plastic case !*

6-2 Replacement of Fuse



Caution : *When make the replacement, should change the right spec. fuse .*

a. Fuse A - Rating : 630 mA

To be protected the circuit from overload current mA range (60 mA, 600 mA).

b. Fuse B - Rating : 10 A

To be protected the circuit from overload current for the " 10 A " range.

- 1) When the mA current range can not operation, please check if the Fuse A is broken or not ?
- 2) When the 10 A current range can not operation, please check if the Fuse B is broken or not ?
- 3) When replace the fuse should take the test leads from the measuring circuit and power off the meter.
- 4) Take the screws away from the down case, loose the housing case, the fuses are install on the fuse socket on the PCB.
- 5) For safety consideration, when replace the fuse according the spec. (should use the approval fuse) and reinstall the cover.
- 6) Make sure the housing case is secured with the screw after replace the fuse.

6-3 Replacement of batteries

- 1) When use the battery power, if the Display show Low battery indicator "  ", it need to change the batteries.
- 2) open the " Battery Cover " (3-14, Fig. 1) away from the instrument and remove the battery.
- 3) Replace with batteries (DC 3V, CR2032 X 2 PCs) and reinstate the cover.
** When install the batteries, should make attention the battery polarity.*
- 4) Make sure the battery cover is secured after changing the batteries.

7. OPTIONAL ACCESSORIES and ADAPTERS

<i>Item</i>	<i>Model</i>
<i>Carrying Case</i>	<i>CA-03, CA-05A</i>
<i>Humidity Adapter</i>	<i>HA-702</i>
<i>Light Adapter</i>	<i>LX-02</i>
<i>EMF Adapter</i>	<i>EMF-824</i>
<i>Pressure Adapter</i>	<i>PS-403</i>
<i>Anemometer Adapter</i>	<i>AM-402</i>
<i>Tachometer Adapter</i>	<i>TA-601</i>
<i>Sound Adapter</i>	<i>SL-406</i>
<i>High Voltage Probe</i>	<i>HV-40</i>

8. PATENT

CHINA : ZL200620012764.3

GERMANY : Nr.202006007329.9

TAIWAN : M299401

JAPAN : 3130269

U.S.A. : PATENT PENDING