



AC/DC True RMS Clamp Meter

ACM-2056

USER'S MANUAL



Contents	Page
1.Safety.....	4
2.Safety Notes.....	4
3.Meter Description.....	5
4.Specifications.....	7
5.Operation.....	9
6.Mode Button.....	13

1. Safety

International Safety Symbols



This symbol, adjacent to another symbol or terminal, indicates the user must refer to the manual for further information.



This symbol, adjacent to a terminal, indicates that, under normal use, hazardous voltages may be present.



Double insulation.

2. Safety Notes

- Do not exceed the maximum allowable input range of any function
- Do not apply voltage to meter when resistance function is selected.
- Set the function switch OFF when the meter is not in use.

Warnings

- Set function switch to the appropriate position before measuring.
- When measuring volts do not switch to current/resistance modes.
- When changing ranges using the selector switch always disconnect the test leads from the circuit under test.
- Do not exceed the maximum rated input limits.

Cautions

Improper use of this meter can cause damage, shock, injury or death. Read and understand this user manual before operating the meter. Always remove the test leads before replacing the battery.

Inspect the condition of the test leads and the meter itself for any damage before operating the meter. Repair or replace any damage before use.

Use great care when making measurements if the voltages are greater than 25VAC rms or 35VDC. These voltages are considered a shock hazard.

Remove the battery if the meter is to be stored for long periods.

Always discharge capacitors and remove power from the device under test before performing Diode, Resistance or Continuity tests.

- Voltage checks on electrical outlets can be difficult and misleading

because of the uncertainty of connection to the recessed electrical contacts. Other means should be used to ensure that the terminals are not "live".

- If the equipment is used in a manner not specified by the manufacturer, the protection provided by the equipment may be impaired.



Input Limits	
Function	Maximum Input
A AC/DC	1000A
V DC, V AC	1000V DC/AC
Frequency, Resistance, Diode, Continuity, Capacitance Test	1000V DC/AC
Temperature (°C/°F)	1000V DC/ AC

3. Meter Description

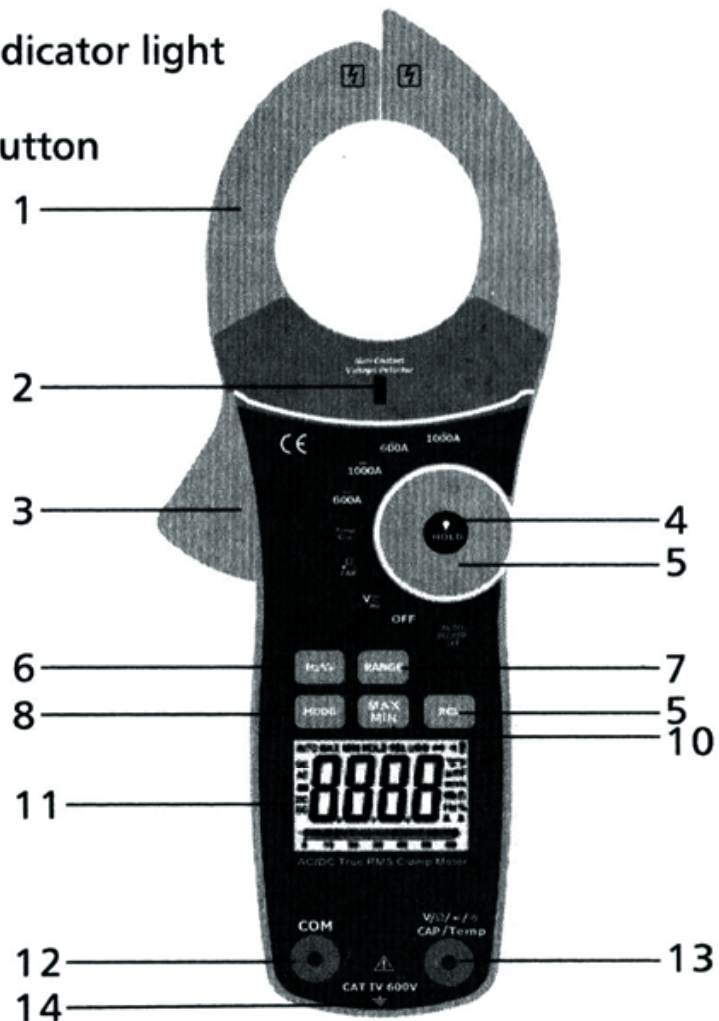
- 1-Current clamp
- 2-Non-contact AC voltage indicator light
- 3-Clamp trigger
- 4-Data Hold and Backlight button
- 5-Rotary Function switch
- 6-Hz% Hlod button
- 7-RANGE select button
- 8-Relative/USB Button
- 9-MIN/MAX Hlod button
- 10-MODE select button
- 11-LCD display
- 12-COM input jack
- 13-VΩCAP TEMP Hz jack
- 14-Battery Cover



AC/DC True RMS Clamp Meter User Manual

HOLD	Data Hold
AUTO	Autoranging
DC	Direct Current
AC	Alternating Current
MAX	Max reading
MIN	Min reading
	Low battery
REL	Relative
USB	Wireless USB
V	Volts (Voltage)
Ω	Ohms (Resistance)
A	Amperes (Current)
F	Farad (Capacitance)
Hz	Hertz (Frequency)
%	Duty Ratio
$^{\circ}\text{F}$ and $^{\circ}\text{C}$	Fahrenheit and Celsius units (Temperature)
n, m, μ , M, k	Unit of measure prefixes: nano, milli, micro, mega, and kilo
	Continuity test
	Diode test



4. Specifications

Function	Range & Resolution	Accuracy (% of reading)
AC Current(50/60Hz)	600.0 AAC	$\pm (2.8 \% + 8 \text{ digits})$
	1000 AAC	$\pm (3.0 \% + 8 \text{ digits})$
AC Current(400Hz)	600.0 AAC	$\pm (5.0 \% + 10 \text{ digits})$
	1000 AAC	$\pm(5.0 \% + 10 \text{ digits})$
DC Current	600.0 ADC	$\pm(2.8 \% + 5 \text{ digits})$
	1000 ADC	$\pm(3.0 \% + 5 \text{ digits})$
DC Voltage	600.0 mVDC	$\pm(0.8\% + 2 \text{ digits})$
	6.000 VDC	$\pm(1.5\% + 2 \text{ digits})$
	60.00 VDC	
	600.0 VDC	
AC Voltage (50-400Hz)	6.000 VAC	$\pm(1.8\% + 8 \text{ digits})$
	60.00 VAC	
	600.0 VAC	
Resistance	600.0 Ω	$\pm(1.0\% + 4 \text{ digits})$
	6.000K Ω	$\pm(1.5\% + 2 \text{ digits})$
	60.00K Ω	
	600.0K Ω	
	6.000M Ω	$\pm(2.5\% + 3 \text{ digits})$
	60.00M Ω	$\pm(3.5\% + 5 \text{ digits})$
Capacitance	40.00nF	$\pm(4.0\% \text{ reading} + 20 \text{ digits})$
	400.0nF	$\pm(3\% \text{ reading} + 5 \text{ digits})$
	4.000 μ F	
	40.00 μ F	
	400.0 μ F	$\pm(4.0\% \text{ reading} + 10 \text{ digits})$
	4000 μ F	$\pm(5.0\% \text{ reading} + 10 \text{ digits})$
Frequency Sensitivity:15Vrms	10-10kHz	$\pm(1.5\% \text{ reading} + 2 \text{ digits})$
Temp (type-K) (probe accuracy not included)	-20.0 to 760.0 $^{\circ}$ C	$\pm(3\% \text{rdg} + 5^{\circ}\text{C})$
	-4.0 to 1400.0 $^{\circ}$ F	$\pm(3\% \text{rdg} + 9^{\circ}\text{F})$

AC/DC True RMS Clamp Meter User Manual

Specifications	Transmitter Unit	Receiver Unit
Display	USB	LED
Controls	Relative/USB Button	
Carrier Frequency (ISM Band)	916.0MHz	N/A
RF O/P Power	10dBm	
Receive Sensitivity		-109dBm
Communication Distance	>100m in an unobstructed field	N/A

Clamp size

Diode Test

Continuity Check

Low Battery Indication

Overrange Indication

Measurements Rate

Input Impedance

Display

AC Current

AC Voltage bandwidth

Operating Temperature

Storage Temperature

Operating Humidity

Storage Humidity

Operating Altitude

Over voltage

Battery

Auto OFF

Dimensions/Weight

Safety

Opening 1.5" (40mm) approx

Test current of 0.3mA typical;

Open circuit voltage 1.5V DC typical.

Threshold <40Ω; Test current <0.5mA

"" is displayed

"OL" is displayed

2 per second, nominal

10MΩ (VDC and VAC)

6000 counts LCD

50-400Hz (AAC)

50-400Hz (VAC)

5 to 40°C(41 to 104°F)

-20 to 60°C(-4 to 140°F)

Max 80% up to 31°C(87°F) decreasing linearly to 50% at 40°C(104°F)

<80%

7000ft. (2000meters) maximum.

Category III 600V

One 9V Battery

approx. 15 minutes

232x77x39mm/271g

For indoor use and in accordance with Overvoltage Category II, Pollution Degree 2. Category II includes local level, appliance, portable equipment, etc., with transient overvoltages less than Overvoltage Cat III

5. Operation

Notices: Read and understand all warning and precaution statements listed in the safety section of this operation manual prior to using this meter. Set the function select switch to the OFF position when the meter is not in use.

AC/DC Current Measurements

Warning: Ensure that the test leads are disconnected from the meter before making current clamp measurements.

- Set the Function switch to the 1000ADC, 600ADC, 1000AAC or 600AAC range.
- If the range of the measured is not known, select the higher range first then move to the lower range if necessary.
- Press the trigger to open jaw. Fully enclose one conductor to be measured.

The clamp meter LCD will display the reading.

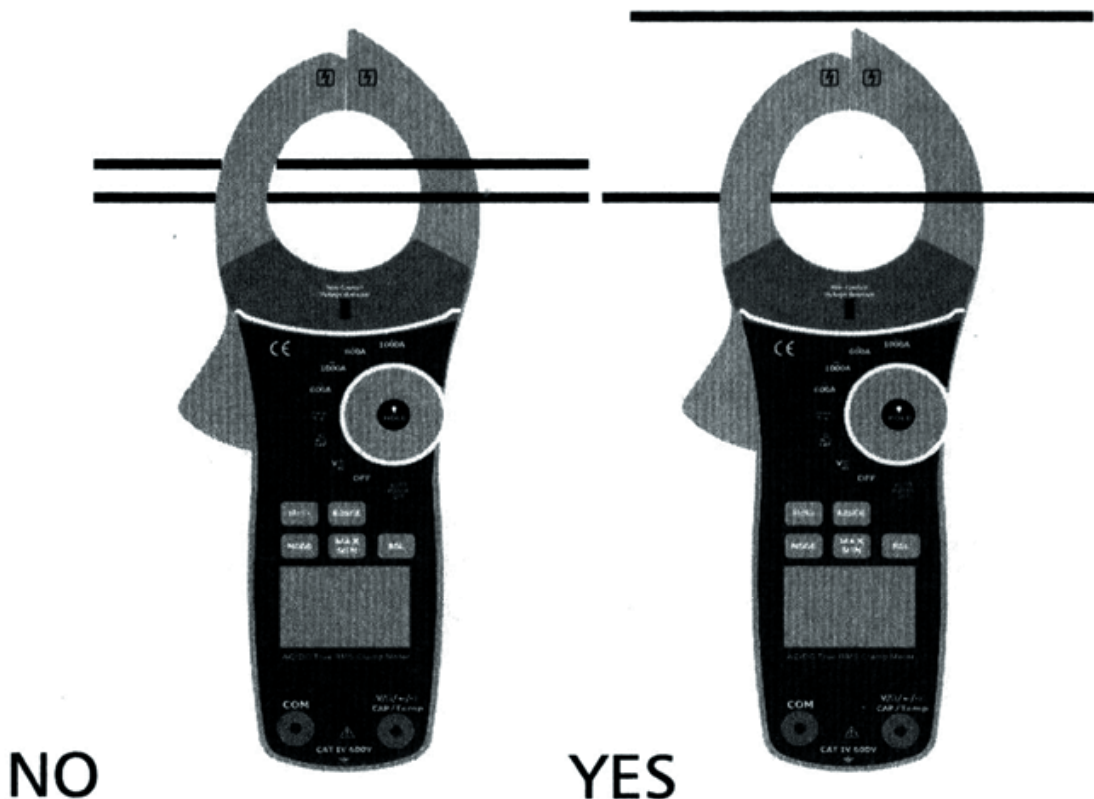

DC/AC Voltage Measurements

- Insert the black test lead into the negative COM terminal and the red test lead into the positive V terminal.
- Set the function switch to the V position.
- Select AC or DC with the MODE button.
- Connect the test leads in parallel to the circuit under test.
- Read the voltage measurement on the LCD display.

Resistance Measurements

- Insert the black test lead into the negative COM terminal and the red test lead into the positive terminal.
- Set the function switch to the Ω \rightarrow \rightarrow CAP position.
- Touch the test probe tips across the circuit or component under test. It is best to disconnect one side of the device under test so the rest of the circuit will not interfere with the resistance reading.
- For Resistance tests, read the resistance on the LCD display.



Diode and Continuity Measurements

- Insert the black test lead banana plug into the negative COM jack and the red test lead banana plug into the positive diode jack.
- Turn the rotary switch to the Ω \rightarrow \rightarrow CAP position.
- Press the MODE button until " \rightarrow " appears in the display.
- Touch the test probes to the diode under test. Forward voltage will indicate 0.4V to 0.7V. Reverse voltage will indicate "OL". Shorted devices will indicate near 0mV and an open device will indicate "OL" in both polarities.



Forward test Reverse test

For Continuity tests, if the resistance is $<40\Omega$, a tone will sound.

Capacitance Measurements

Warning: To avoid electric shock, disconnect power to the unit under test and discharge all capacitors before taking any capacitance measurements. Remove the batteries and unplug the line cords.

- Set the rotary function switch to the Ω \rightarrow \rightarrow CAP position.
- Insert the black test lead banana plug into the negative (COM) jack. Insert the red test lead banana plug into the positive (V) jack.
- Touch the test leads to the capacitor to be tested.
- Read the capacitance value in the display.

Frequency/duty Cycle Measurements (electronic)

- Set the rotary function switch to "V" position.
- Select ACV with the MODE button
- Press the Hz/% button to indicate "Hz" in the display.
- Insert the black lead banana plug into the negative COM jack and the red test lead banana plug into the positive Hz jack.
- Touch the test probe tips to the circuit under test.
- Read the frequency on the display.
- Press the Hz/% button again to indicate "%" on the display. Read the % of duty cycle on the display.

Temperature Measurements

Warning: To avoid electric shock, disconnect both test probes from any source of voltage before making a temperature measurement.

- Set the function switch to TEMP.
- Insert the Temperature Probe into the negative (COM) and the V jacks, making sure to observe the correct polarity.
- Select °C or °F with the MODE button.
- Touch the Temperature Probe head to the part whose temperature you wish to measure. Keep the probe touching the part under test until the reading stabilizes (about 30 seconds).
- Read the temperature in the display. The digital reading will indicate the proper decimal point and value.

Warning: To avoid electric shock, be sure the thermocouple has been removed before changing to another measurement function.

Non-Contact AC Voltage Measurements

Warning: Risk of Electrocution. Before use, always test the Voltage Detector on a known live circuit to verify proper operation.

- Touch the probe tip to the hot conductor or insert into the hot side of the electrical outlet.
- If AC voltage is present, the detector light will illuminate.

NOTE: The conductors in electrical cord sets are often twisted. For best results, rub the probe tip along a length of the cord to assure placing the tip in close proximity to the live conductor.

NOTE: The detector is designed with high sensitivity. Static electricity or other sources of energy may randomly trip the sensor. This is normal operation.

6.Mode Button

To select DC/ACV,OHM/ Diode/Continuity/CAP, °C/°F.

MIN & MAX Recording Button

Press MIN/MAX to enter MIN, MAX Recording mode (manual range only). Select the proper range before selecting MIN MAX to ensure that the MIN/MAX reading will not exceed the testing range. Press once to select MIN. Press again to select MAX. and press again release MIN/MAX recording function.

Rel Button

For DCA Zero & Offset adjustment.

Data Hold Button

To freeze the LCD meter reading, press the data hold button. The data hold button is located on the left side of the meter (top button). While data hold is active, the HOLD display icon appears on the LCD. Press the data hold button again to return to normal operation.
Note: The HOLD feature will activate when the Backlight is turned on. Press the HOLD key again to exit Hold.

Range Button

When the meter is first turned on, it automatically goes into AutoRanging. This automatically selects the best range for the measurements being made and is generally the best mode for most measurements. For measurement situations requiring that a range be manually selected, perform the following:

- Press the RANGE button. The "Auto Range" display indicator will turn off, The "Manual Range" display indicator will turn on
- Press the RANGE button to step through the available ranges until you select the range you want.
- Press and hold the RANGE button for 2 seconds to exit the Manual Ranging mode and return to AutoRanging.

Wireless USB

The Wireless USB for long-distance communications. Press and USB the REL/USB button for 2 seconds to turn the Wireless USB on. The USB icon appears on the LCD.

Press the REL/USB button again for 2 seconds to return to normal operation.

Backlight Button

The backlight function illuminates the display and is used when the ambient light is too low to permit viewing of the displayed readings. Press the  button for two seconds to turn the backlight on and press the button a second time to turn the backlight off.

Battery Replacement

- Remove the one rear Phillips head screw.
- Open the battery compartment.
- Replace the Requires One 9V battery.
- Re-assemble the meter.

