



AC/DC TRUE RMS CLAMP METER

ACM-2036

User's Manual



Safety

International Safety Symbols



This symbol, adjacent to another symbol or terminal, indicates the user must refer to the manual for further information.



This symbol, adjacent to a terminal, indicates that, under normal use, hazardous voltages may be present



Double insulation

SAFETY NOTES

- ☒ Do not exceed the maximum allowable input range of any function
- ☒ Do not apply voltage to meter when resistance function is selected.
- ☒ Set the function switch OFF when the meter is not in use.

WARNINGS

- ☒ Set function switch to the appropriate position before measuring.
- ☒ When measuring volts do not switch to current/resistance modes.
- ☒ When changing ranges using the selector switch always disconnect the test leads from the circuit under test.
- ☒ Do not exceed the maximum rated input limits.

CAUTIONS

Improper use of this meter can cause damage, shock, injury or death. Read and understand this user manual before operating the meter.

Always remove the test leads before replacing the battery.

Inspect the condition of the test leads and the meter itself for any damage before operating the meter. Repair or replace any damage before use.

Use great care when making measurements if the voltages are greater than 25VAC rms or 35VDC. These voltages are considered a shock hazard.

Remove the battery if the meter is to be stored for long periods.

Always discharge capacitors and remove power from the device under test before performing Diode, Resistance or Continuity tests.

☒ Voltage checks on electrical outlets can be difficult and misleading because of the uncertainty of connection to the recessed electrical contacts. Other means should be used to ensure that the terminals are not "live".

☒ If the equipment is used in a manner not specified by the manufacturer, the protection provided by the equipment may be impaired.

Input Limits	
Function	Maximum Input
A AC, VDC	200A (PEAK 282.8A)
V DC, V AC	600V DC/AC
Resistance, Continuity Test	600V DC/AC

Meter Description

1. Current clamp & Non-contact AC voltage detector probe tip
2. Flashlight
3. Non-contact AC voltage(NCV) indicator light
4. Flashlight on/off button
5. Rotary Function swith
6. Clamp trigger
7. LCD display
8. Select Peek hold, MAX/MIN Hold, DCA Zero,DC/ACV function button
 - Peak Hold function (only ACA range)
 - DCA Zero (only DCA range)
 - MAX/MIN Hold function (Use to DCA,DCV,ACV, Resistance range)
 - DC/ACV (select DC Vor ACV)
9. Data Hold & Backlight button
10. COM input jack
11. V Ω jack
12. Battery Cover

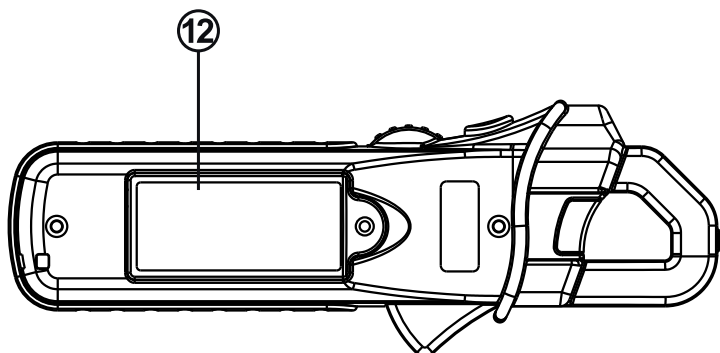
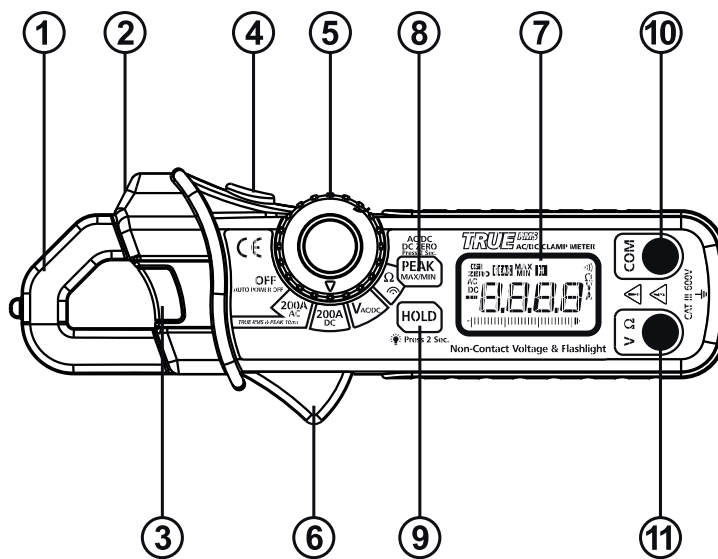

1. **AC DC** AC (alternating current) and DC (direct current)
2. **■** Minus sign
3. **1.8.8.8** 2000 to 9999 count measurement reading
4. **PEAK/ MAX/MIN** PEAK/MAX/MIN mode
5. **•)))** Audible Continuity
6. **HOLD** Data Hold mode
7. **BAT** Low Battery icon
8. **V,A,Ω** Units of measure list

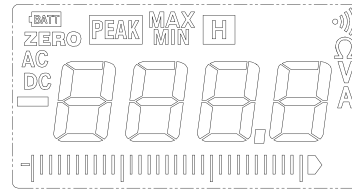

Specifications

Function	Range & Resolution	Accuracy (% of reading)
AC Current (50/60 Hz) True RMS	200.0 AAC	± (2.5% + 8 digits)
DC Current	200.0 ADC	± (2.0% + 5 digits)
DC Voltage	600.0 VDC	± (1.0% + 2 digits)
AC Voltage True RMS	600.0 VAC	± (1.5% +8 digits)
Resistance	999.9 Ω	± (1.5% +8 digits)

Clamp size	Opening 0.7" (18mm) approx
Continuity Check	Threshold <30Ω; Test current < 0.5mA
Low Battery Indication	"BAT" is displayed
Overrange Indication	"OL " is displayed
Measurements Rate	10 times/Sec. for reading & 32 segments bar graph updates 40 times (at DCA,DCV & Resistance Measurement)
Input Impedance	1.0MΩ (VDC and VAC)
Display	2000 counts to 9999 counts LCD display with backlight
AC Current bandwidth	50/400Hz (True rms)
AC Voltage bandwidth	50/400Hz (True rms)
Peak hold	Captures peaks <10ms
Max/Min hold	Captures times <50ms
Operating Temperature	14 to 122°F (-10 to 50°C)
Storage Temperature	-14 to 140°F (-30 to 60°C)
Relative Humidity	90%(0°C to 30°C); 75%(30°C to 40°C); 45%(40°C to 50°C)
Altitude	Operating: 3000m; Storage 10,000m
Over voltage	Category III 600V/ Category IV 300V
Battery	Two 1.5V "AAA" Batteries
Auto Power Off(APO)	Without pressing any function buttons is approx. 10 minutes APO. Pressing any function buttons is disable APO.
Dimensions/Weight	164x65x32mm/175g
Safety	For indoor use and in accordance with the requirements for double Insulation to IEC1010-1 (1995): EN61010-1 (1995) Overvoltage Category III 600V and Category IV 300V, Pollution Degree 2.

Operation

NOTICES: Read and understand all **warning** and **precaution** statements listed in the safety section of this operation manual prior to using this meter. Set the function select switch to the OFF position when the meter is not in use.

AC Current Measurements

- 1) Set the Function switch to the ACA range.
- 2) Press the jaw trigger and clamp around, fully enclosing a single conductor. Do not allow a gap between the two halves of the jaw. Refer to the diagram at right for the correct way to enclose a single conductor.
- 3) Read the ACA value on the LCD.



DC Current Measurements

- 1) Set the Function switch to the DCA range.
- 2) Press the DCA ZERO key to null the meter display.
- 3) Press the Trigger to open the current sense Jaw.
- 4) Fully enclose the conductor to be measured. Do not allow a gap between the two halves of the jaw.
- 5) Read the DCA value on the LCD.

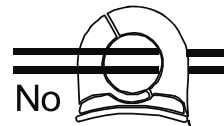

AC/DC Voltage Measurements

1. Insert the black test lead into the negative **COM** terminal and the red test lead into the positive **V** terminal.
2. Set the function switch to the V position.
3. Press AC/ DC button 2 Sec. Select AC/DC.
4. Connect the test leads in parallel to the circuit under test.
5. Read the voltage measurement on the LCD display.

Resistance and Continuity Measurements

1. Insert the black test lead into the negative **COM** terminal and the red test lead into the positive terminal.
2. Touch the test probe tips across the circuit or component under test. It is best to disconnect one side of the device under test so the rest of the circuit will not interfere with the resistance reading.
3. For Resistance tests, read the resistance on the LCD display & if the resistance is $< 30\Omega$, a tone will sound.

Operation

NOTICES: Read and understand all **warning** and **precaution** statements listed in the safety section of this operation manual prior to using this meter. Set the function select switch to the OFF position when the meter is not in use.

AC Current Measurements

- 1) Set the Function switch to the ACA range.
- 2) Press the jaw trigger and clamp around, fully enclosing a single conductor. Do not allow a gap between the two halves of the jaw. Refer to the diagram at right for the correct way to enclose a single conductor.
- 3) Read the ACA value on the LCD.



DC Current Measurements

- 1) Set the Function switch to the DCA range.
- 2) Press the DCA ZERO key to null the meter display.
- 3) Press the Trigger to open the current sense Jaw.
- 4) Fully enclose the conductor to be measured. Do not allow a gap between the two halves of the jaw.
- 5) Read the DCA value on the LCD.

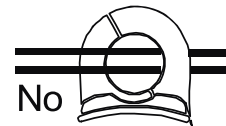

AC/DC Voltage Measurements

1. Insert the black test lead into the negative **COM** terminal and the red test lead into the positive **V** terminal.
2. Set the function switch to the V position.
3. Press AC/ DC button 2 Sec. Select AC/DC.
4. Connect the test leads in parallel to the circuit under test.
5. Read the voltage measurement on the LCD display.

Resistance and Continuity Measurements

1. Insert the black test lead into the negative **COM** terminal and the red test lead into the positive terminal.
2. Touch the test probe tips across the circuit or component under test. It is best to disconnect one side of the device under test so the rest of the circuit will not interfere with the resistance reading.
3. For Resistance tests, read the resistance on the LCD display & if the resistance is $< 30\Omega$, a tone will sound.

Non-Contact AC Voltage Measurements

WARNING: Risk of Electrocution. Before use, always test the Voltage Detector on a known live circuit to verify proper operation

1. Touch the probe tip to the hot conductor or insert into the hot side of the electrical outlet.
2. If AC voltage is present, the detector light will illuminate.

NOTE: The conductors in electrical cord sets are often twisted. For best results, rub the probe tip along a length of the cord to assure placing the tip in close proximity to the live conductor.

NOTE: The detector is designed with high sensitivity. Static electricity or other sources of energy may randomly trip the sensor. This is normal operation

Flashlight

Press and hold the top button to turn the flashlight on. Release the button to turn the flashlight off.

Data Hold & Backlight button

To freeze the current reading on the LCD, press the “**Data Hold & Backlight**” key. The word HOLD will appear on the LCD while the meter is in the Data Hold mode. To release the Data Hold function and return the meter to normal operation, press the “Hold Backlight” key again. The word HOLD will switch off. The backlight function illuminates the display and is used when the ambient light is too low to permit viewing of the displayed readings. Press the **Data Hold & Backlight** button for 2 seconds to turn the backlight on and press the button a second time to turn the backlight off.

Peak Hold (only ACA 200A Range)

The Peak Hold function captures the peak AC/DC current 10~282.8A. The meter can capture peaks as fast as <10 milliseconds in duration.

MAX/MIN (DCA,DCV,ACV, Resistance range)

1. Press the **MAX/MIN** key to activate the MAX/MIN recording mode. The display icon "**MAX**" will appear. The meter will display and hold the maximum reading and will update only when a new “max” occurs.
2. Press the **MAX/MIN** key and “**MIN**” will appear. The display icon "**MIN**" will appear. The meter will display and hold the minimum reading and will update only when a new “min” occurs.
3. Press the **MAX/MIN** key and a “**MAX MIN**” will appear. The meter will display the present reading, but will continue to update and store the max and min readings.
4. To exit MAX/MIN mode press and hold the **MAX/MIN** key for 2 seconds.

DCA ZERO

The DC Zero feature removes offset values and improves accuracy for DC current measurements. To perform a zero, select ADC and with no conductor in the jaw:

1. Press the DC ZERO button 2 Sec. to zero the display. "ZERO" will appear in the display. The offset value is now stored and removed from all measurements.
2. To view the stored value, press the DC ZERO button. "ZERO" will flash and the stored value will be displayed.
3. To exit this mode, press and Hold the ZERO button until "ZERO" is no longer in the display.

True RMS (ACA or ACV)

The term stands for "Root-Mean-Square," which represents the method of calculation of the voltage or current value. Average responding multimeters are calibrated to read correctly only on sine waves and they will read inaccurately on non-sine wave or distorted signals. True rms meters read accurately on either type of signal.

Battery Replacement

1. Remove the one rear Phillips head screw
2. Open the battery compartment
3. Replace the Requires two "AAA" batteries (UM4 R03)
4. Re-assemble the meter